

BAND SAW

SX300 S

Fixed table

Constructeur : DADAUX					
BERSAILLIN 03 84 85 51 71					
N°	<input type="text"/>	Volts	<input type="text" value="380"/>	<input type="text" value="~"/>	
Type	<input type="text" value="SX 300 S"/>	Fréquence	<input type="text" value="50 Hz"/>		
	IP	<input type="text" value="55"/>			
<input type="radio"/>	Date de fabrication	<input type="text"/>			<input type="radio"/>
FABRICATION FRANCAISE					



**CONSTRUCTION & COMMERCE DE
MATERIEL POUR L'ALIMENTATION**

LE BOUCHAUD – 39800 BERSAILLIN
Tél. 03-84-85-51-71 – Fax 03-84-85-53-92
(Fax international : 33-3-84-85-53-92)

COMPONENTS OF THE SX 300 3 BAND SAW

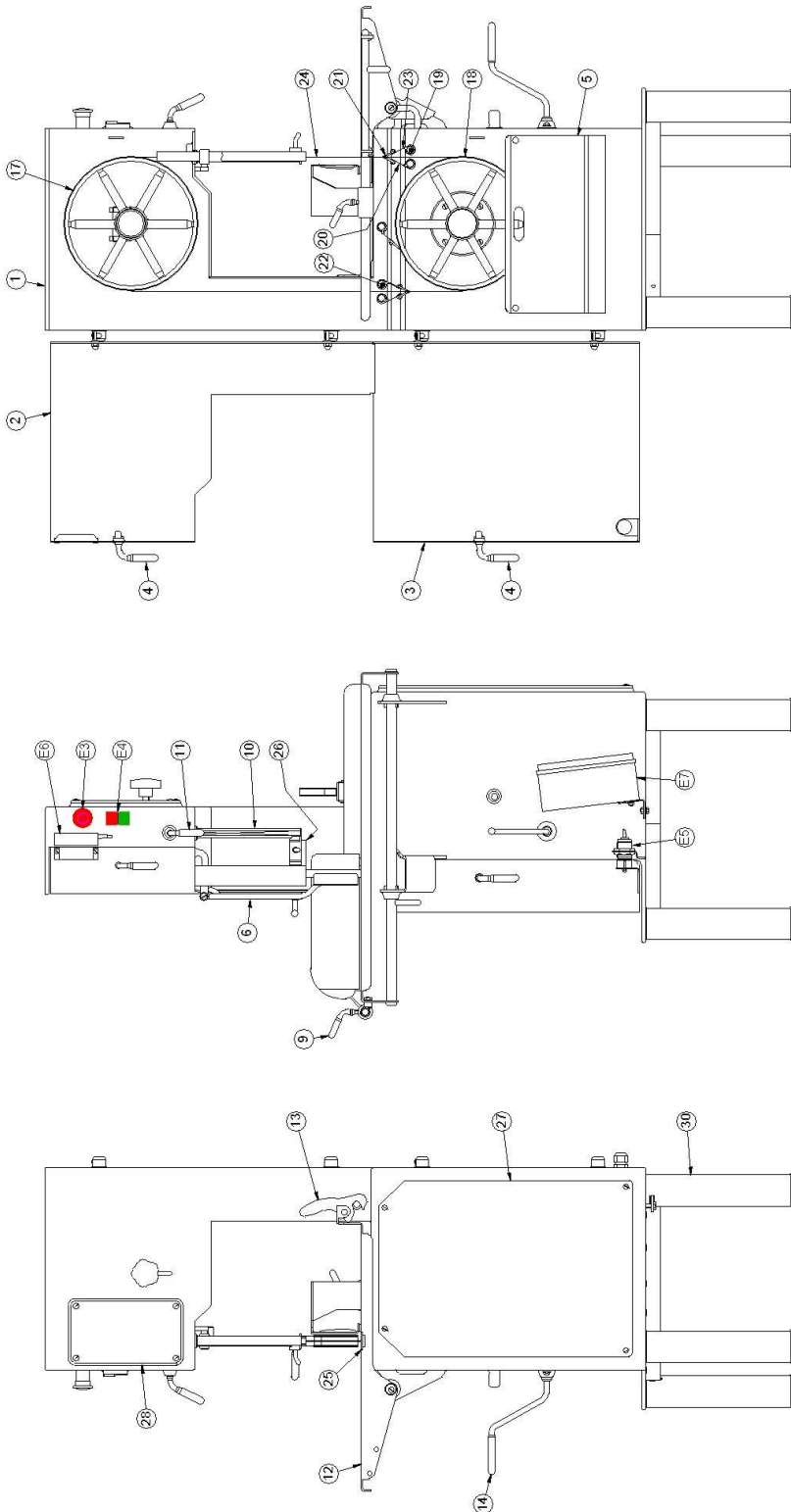

1. BATI	21. RACLEUR LAME ET POULIE
2. PORTE ACCES POULIE SUPERIEURE	22. SUPPORT RACLEUR LONG
3. PORTE ACCES POULIE INFERIEURE	23. LAME RESSORT RACLEUR TYPE 1
4. MANIETTE FERMETURE PORTE	24. LAME
5. BAC A DECHETS	25. GUIDE LAME INFERIEUR
6. POUSSOIR ARTICULE	26. GUIDE LAME SUPERIEUR
7. GUIDE EPAISSEUR COUPE	27. PORTE ACCES MOTEUR
8. GLISSIERE GUIDE EPAISSEUR COUPE	28. PORTE ACCES TETE
9. VIS MAINTIEN GUIDE EPAISSEUR COUPE	29. RENFORT PLATEAU
10. PROTEGE LAME AJUSTABLE	30. PIED REGLABLE
11. AXE BLOCAGE PROTEGE LAME	E1. CABLE SOUPLE D' ALIMENTATION
12. PLATEAU PIVOTANT	E2. PRISE D' ALIMENTATION
13. POIGNEE MAINTIEN PLATEAU	E3. BOUTON POUSSOIR ARRET D' URGENCE
14. MANIETTE TENDEUR LAME	E4. BOUTON POUSSOIR MARCHE / ARRET
15. VIS REGLAGE POULIE SUPERIEURE	E5. INTERRUPTEUR DE SECURITE MAGNETIQUE PORTE INFERIEURE
16. MANIETTE BLOCAGE VIS REGLAGE POULIE SUPERIEURE	E6. INTERRUPTEUR DE SECURITE MAGNETIQUE PORTE SUPERIEURE
17. POULIE SUPERIEURE	E7. COFFRET ELECTRIQUE
18. POULIE INFERIEURE	
19. SUPPORT RACLEUR COURT	
20. LAME RESSORT RACLEUR TYPE 2	

SIZE OF THE SX 300 3 BAND SAW

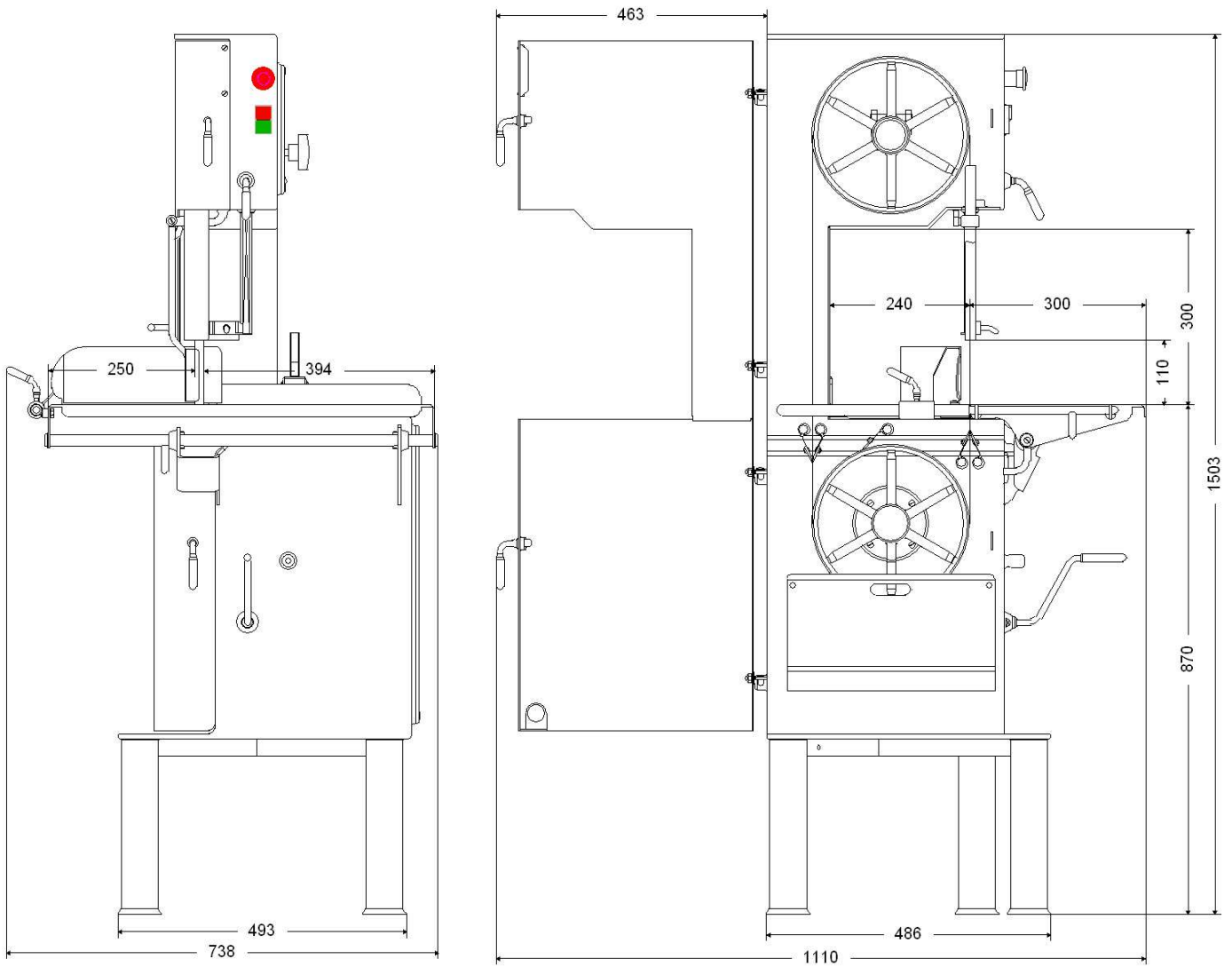

SPECIFICATIONS :

PULLEY DIAMETER (mm)	270
MASS (Kg)	120
ENGINE POWER (Kw)	1.5
SIZE OF THE BLADE (mm)	2170 x 16 x 0.5

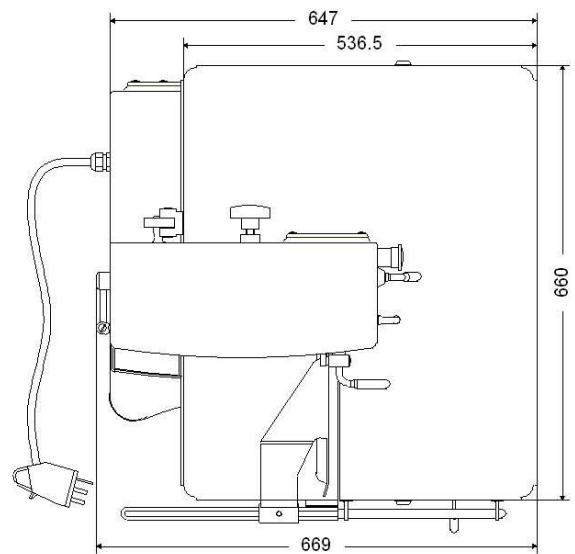

MOVING OF THE SX 300 S BAND SAW

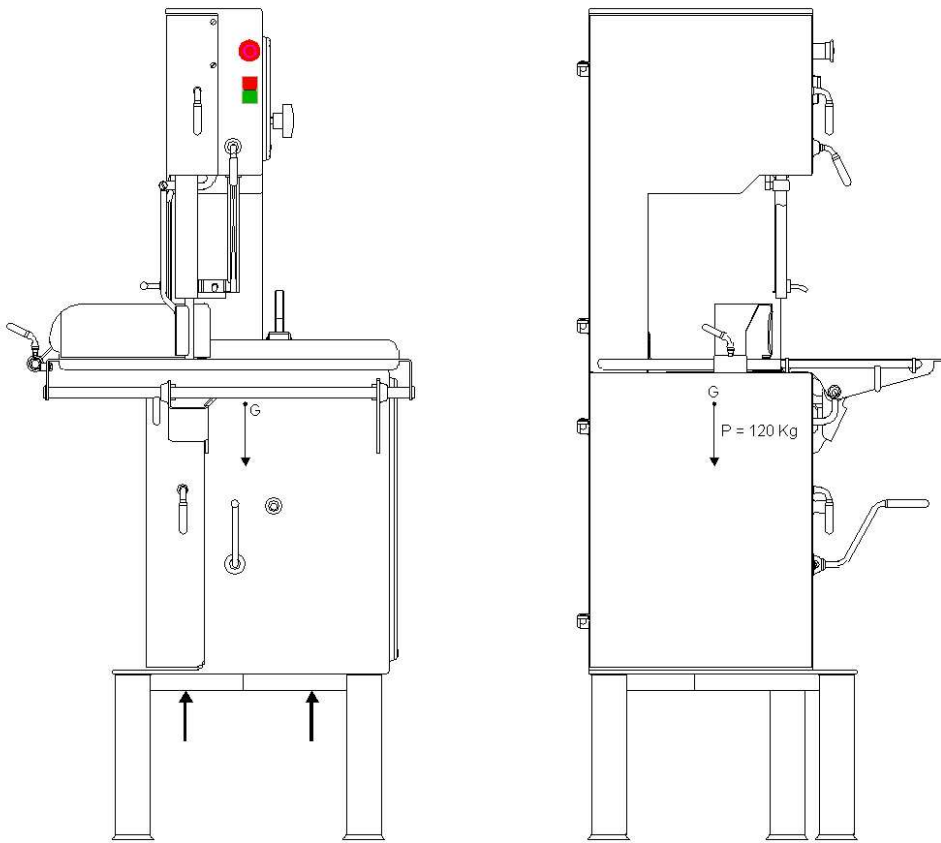

TO FREE THE BAND SAW FROM ITS PACKAGING OR TO SET IT UP, PLACE THE LIFT-TRUCK FORKS BETWEEN FEET AS INDICATED BY THE ARROWS.

THE NEEDED SPACE FOR THE USER TO USE THE BAND SAW

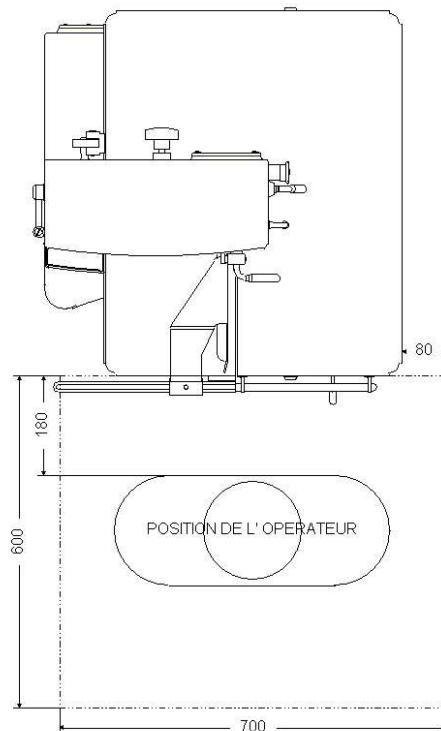

EXPLODED VIEW
BACK OF THE MACHINE
SX 300 S

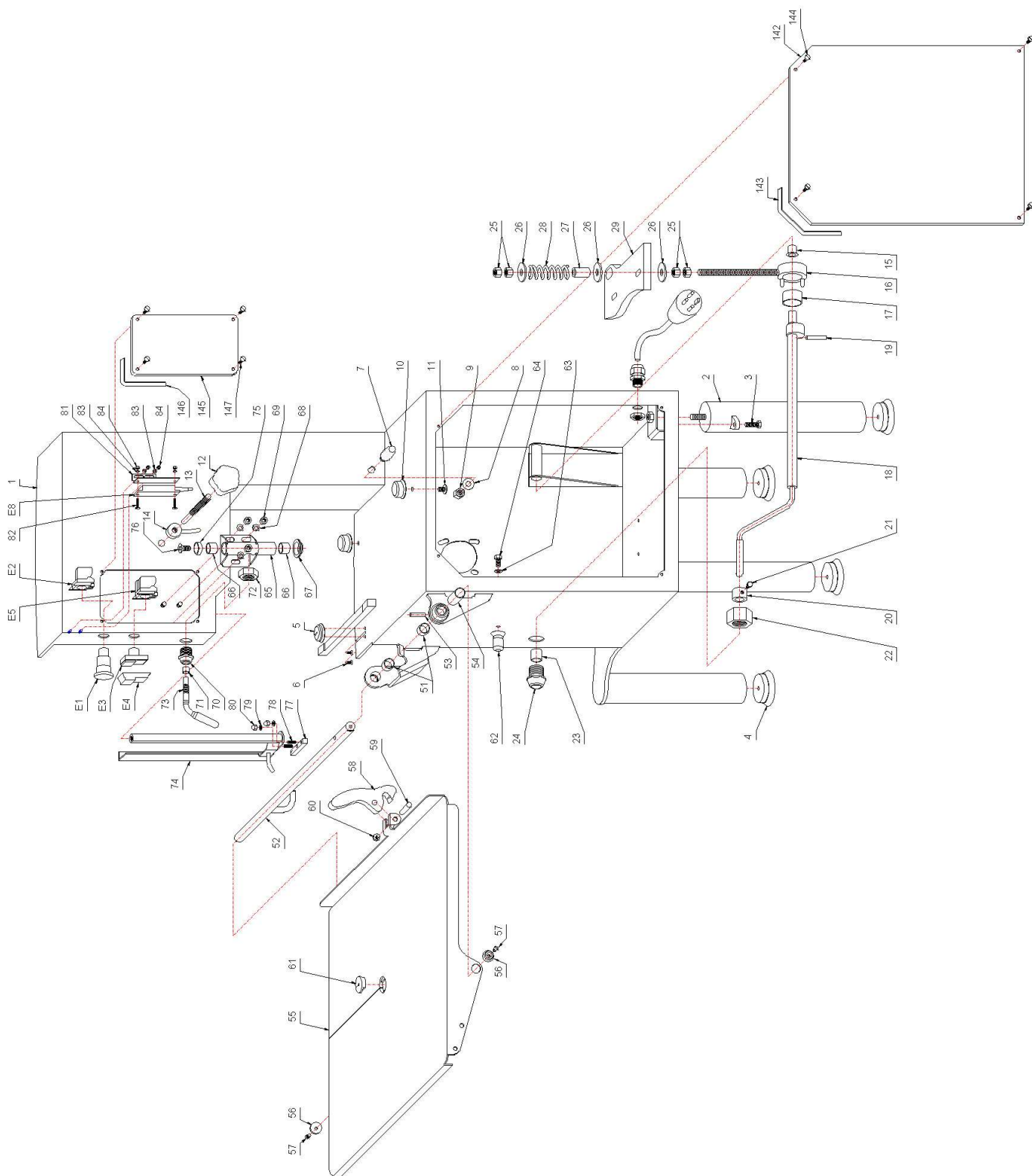

EXPLODED VIEW
INSIDE THE MACHINE
SX 300

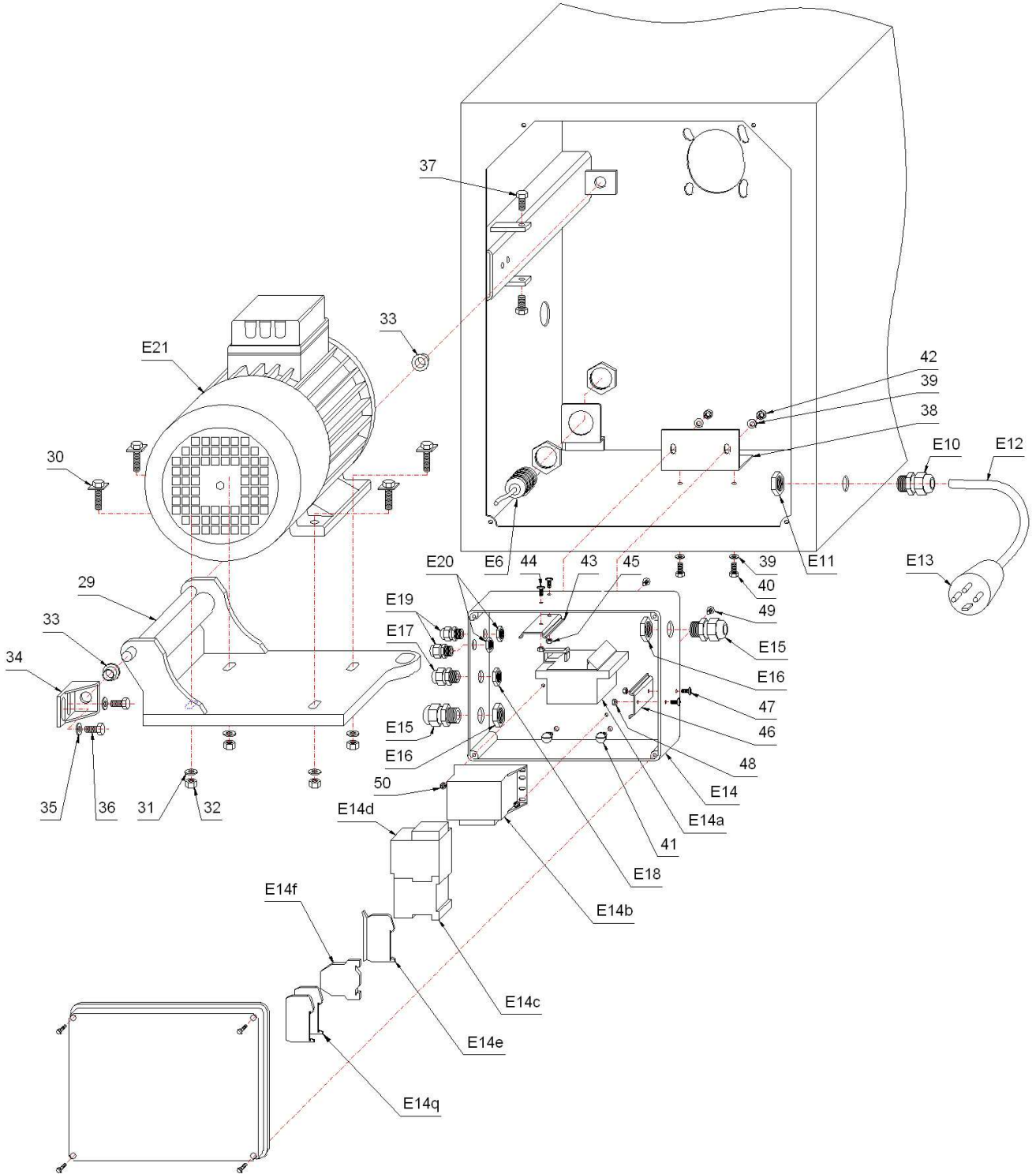

EXPLODED VIEW
THE FRONT OF THE MACHINE
SX 300 S

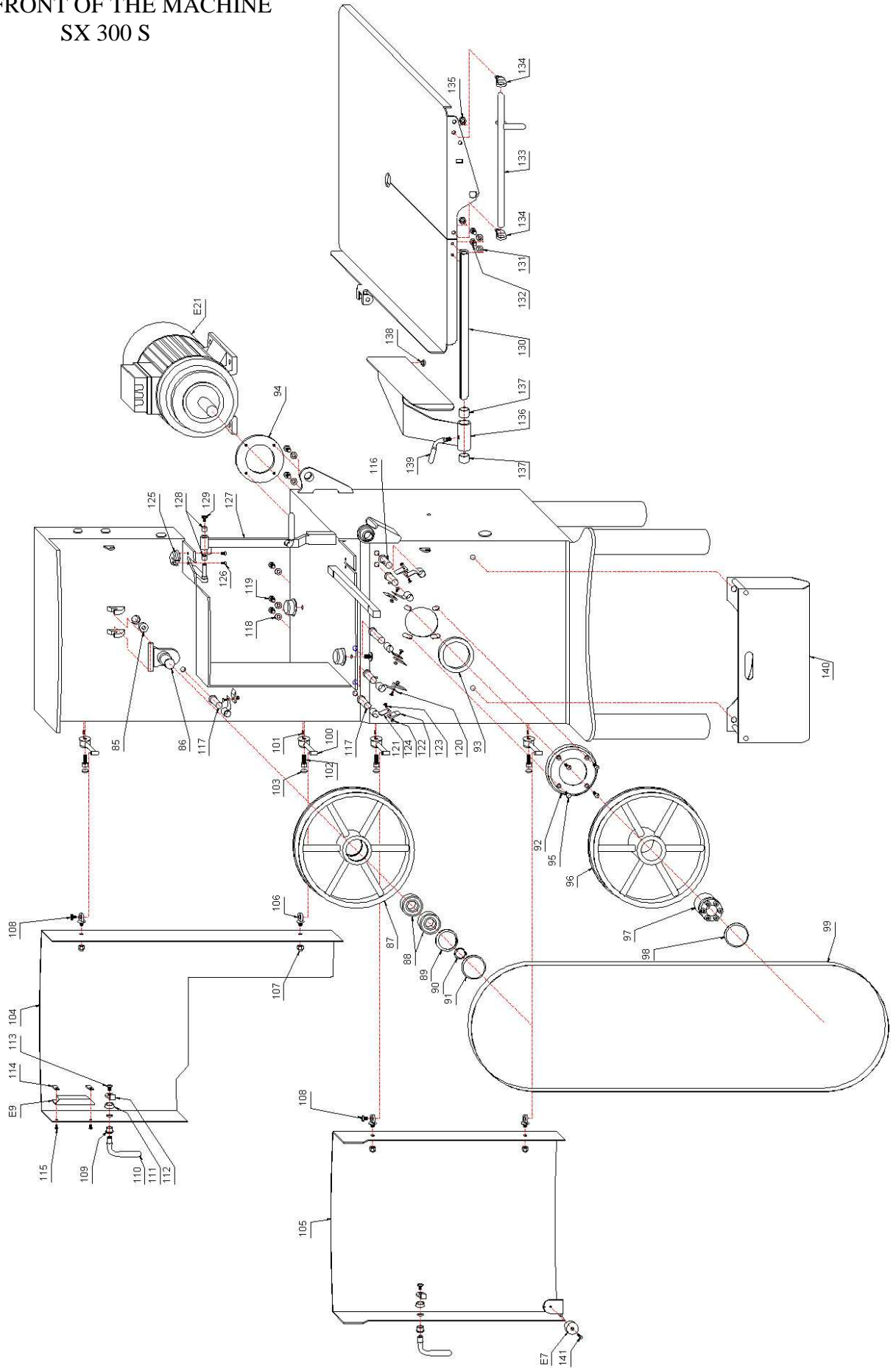

REP.	NB.	DESIGNATION	DIMENSION	MATTER
1	1	FRAME		STAINLESS STEEL 304
2	1	ADJUSTABLE FOOT		STAINLESS STEEL 304
3	1	HEXAGONAL HEADED SCREW	M8 - 25	STAINLESS STEEL A2
4	4	CONNECTOR FOOT MACHINE		EPDM
5	1	FINGERS PROTECT		PEhd 500
6	2	SPRING BEVEL HEADED SCREW	M5 - 10	STAINLESS STEEL A2
7	1	CLAMPING LINE HANDLE PLATE		STAINLESS STEEL 304
8	1	FLAT WASHER	d12 - D24 - e2,5	STAINLESS STEEL A2
9	1	HEXAGONAL NUT	M12	STAINLESS STEEL A2
12	2	BLOC SUPPORT SWIEVELLING BASE		PEhd 500
13	2	STOVED CAP SCREW	M8 - 12	STAINLESS STEEL A2
14	1	HANDWHEEL WITH LOBES	M12	BAKELITE
15	1	ADJUSTING SCREW TOP PULLEY		STAINLESS STEEL A2
16	1	CLAMPING HANDLE ADJUSTING SCREW TOP PULLEY		STAINLESS STEEL 304
17	1	FRICTION RING WITH FLANGE	FMB 16 17 DU-B	BRONZE+PTFE
18	1	EYE SCREW ADJUSTING TENSION BLADE		STAINLESS STEEL 304 + A2
19	1	FRICTION RING	MB 37 20 DU	STEEL+BRONZE+PTFE
20	1	ADJUSTING SHAFT		STAINLESS STEEL 304
21	1	ELASTIC PIN	d8 * lg 40	STEEL
22	1	CLAMPING RING ADJUSTING SHAFT		STAINLESS STEEL 304
23	1	HEXAGONAL HEADED SCREW	M6 - 10	STAINLESS STEEL A2
24	1	HEXAGONAL NUT	M30	STAINLESS STEEL A2
25	1	FRICTION RING	MB 20 15 DU-B	BRONZE+PTFE
26	1	CLAMPING HANDLE BLADE		STAINLESS STEEL 304
27	4	HEXAGONAL NUT	M12	STAINLESS STEEL A2
28	1	FLAT WASHER	d12 - D40 - e3	STAINLESS STEEL A2
29	1	COMPRESSION SPRING		STAINLESS STEEL 302
30	1	PLATE OF MOTOR		STEEL
31	4	BRAKED HEXAGONAL HEADED SCREW	M8 - 40	STAINLESS STEEL A2
32	4	FLAT WASHER	d8 - D16 - e1,5	STAINLESS STEEL A2
33	4	HEXAGONAL NUT	M8	STAINLESS STEEL A2
34	2	FRICTION RING WITH FLANGE	FMB 14 12 DU	STEEL+BRONZE+PTFE
35	1	ADJUSTING BEARING PLATE OF MOTOR		STAINLESS STEEL 304
36	2	FLAT WASHER	d8 - D16 - e1,5	STAINLESS STEEL A2
37	2	HEXAGONAL HEADED SCREW	M8 - 16	STAINLESS STEEL A2
38	2	HEXAGONAL HEADED SCREW	M8 - 30	STAINLESS STEEL A2
39	1	FIXING ANGLE ELECTRIC BOX		STAINLESS STEEL 304
40	2	FLAT WASHER	d6 - D12 - e1,2	STAINLESS STEEL A2
41	2	HEXAGONAL HEADED SCREW	M6 - 10	STAINLESS STEEL A2
42	1	FRICTION RING	MB 20 15 DU-B	BRONZE+PTFE

REP.	NB.	DESIGNATION	DIMENSION	MATTER
43	2	STOVED CAP SCREW	M6 - 12	STAINLESS STEEL A2
44	2	HEXAGONAL NUT	M6	STAINLESS STEEL A2
45	1	RAIL DIN BAS	long 65	STEEL
46	2	STOVED CAP SCREW	M4 - 10	STEEL
47	2	HEXAGONAL NUT	M4	STEEL
48	1	RAIL DIN BAS	long 65	STEEL
49	2	STOVED CAP SCREW	M4 - 10	STEEL
50	2	HEXAGONAL NUT	M4	STEEL
51	2	STOVED CAP SCREW	M4 - 10	STEEL
52	2	HEXAGONAL NUT	M4	STEEL
53	2	FRICTION RING	MB 20 15 DU-B	BRONZE+PTFE
54	1	BASE ROTATION AXIS		STAINLESS STEEL 304
55	2	BASE KEEPING PIN	D8 long 30	STAINLESS STEEL A2
56	1	SWIVELING BASE		STAINLESS STEEL 304
57	2	STEP FIXING BASE		STAINLESS STEEL 304
58	2	FIXING ROTATION AXIS		STAINLESS STEEL 304
59	2	SPRING BEVEL HEADED SCREW	M6 - 12	STAINLESS STEEL A2
60	1	HOLDING PLATE GRASP		PEhd 500
61	1	ROTATIONS AXIS HOLDING PLATE		STAINLESS STEEL 304
62	1	STOVED CAP SCREW	M6 - 10	STAINLESS STEEL A2
63	1	BLADE GUIDE		STAINLESS STEEL 304 traité
64	1	THRUST SWIVELING BASE		PEhd 500
65	1	FLAT WASHER	d8 - D16 - e1,5	STAINLESS STEEL A2
66	1	HEXAGONAL HEADED SCREW	M8 - 16	STAINLESS STEEL A2
67	1	BEARING TRANSLATION BLADE GUARD		STAINLESS STEEL 304
68	2	FRICTION RING	MB 20 15 DU-B	BRONZE+PTFE
69	1	GLAND RING BLADE GUARD		PEhd 500
70	3	FLAT WASHER	d8 - D16 - e1,5	STAINLESS STEEL A2
71	3	HEXAGONAL NUT	M8	STAINLESS STEEL A2
72	1	PLATE PASS BLOCKING AXIS BLADE GUARD		STAINLESS STEEL 304
73	1	FRICTION RING	MB 12 10 DU-B	BRONZE+PTFE
74	1	HEXAGONAL NUT LOW	M24	STAINLESS STEEL A2
75	1	BLOCKING AXIS BLADE GUARD		STAINLESS STEEL 304
76	1	ADJUSTING PROTECT BLADE		STAINLESS STEEL 304
77	1	THRUST PROTECT BLADE		PUR
78	1	CAP SCREW CHC	M10 - 20	STAINLESS STEEL A2
79	1	UPPER GUIDE BLADE		STAINLESS STEEL 304 treated
80	2	GRUB SCREW HC	M6 - 16	STAINLESS STEEL A2
81	2	FLAT WASHER	d6 - D12 - e1,2	STAINLESS STEEL A2
82	2	HEXAGONAL NUT BLIND	M6	STAINLESS STEEL A2

REP.	NB.	DESIGNATION	DIMENSION	MATTER
83	1	UPPER DOOR SAFETY CATCHER SUPPORT		STAINLESS STEEL 304
84	2	CAP SCREW CHC	M4 - 20	STAINLESS STEEL A2
85	4	FLAT WASHER	D4 – D8 – e0,8	STAINLESS STEEL A2
86	4	HEXAGONAL NUT	M4	STAINLESS STEEL A2
87	1	LIPPED JOINT	BA 10 x 22 x 8	NBR
88	1	UPPER PULLEY REST		STAINLESS STEEL 304
89	1	UPPER PULLEY		STAINLESS STEEL 304
90	2	BALL BEARING	6205 - 2RS1	STAINLESS STEEL
91	1	CIRCLIPS FOR REAMING	D52 - e2	X35 Cr Mo 17
92	1	CIRCLIPS FOR SHAFT	d25 - e1,2	X35 Cr Mo 17
93	1	COVER BEARINGS UPPER PULLEY		PEhd 500
94	1	GLAND RING LOWER PULLEY		PEhd 500
95	1	DOUBLE LIPPED JOINT	BASL 68 * 87 * 8	NBR
96	1	BACK GLAND RING BOTTOM PULLEY		PEhd 500
97	4	SPRING BEVEL HEADED SCREW	M6 - 20	STAINLESS STEEL A2
98	1	BOTTOM PULLEY		STAINLESS STEEL 304
99	1	EXPANDING BOSS SELF CENTERED	A5 - 56 - 24	STEEL
100	1	COVER BOSS BOTTOM PULLEY		PEhd 500
101	1	BLADE	2170 x 16 x 0,5	STAINLESS STEEL
102	4	HINGE FRAME		STAINLESS STEEL 304
103	4	CYLINDRICAL PIN	d4 long 10	STAINLESS STEEL A2
104	4	CHC HEADED SCREW	M8 - 20	STAINLESS STEEL A2
105	4	SCREW CAP FIXING HINGE FRAME		PEhd 500
106	1	UPPER PULLEY ACCESS DOOR		STAINLESS STEEL 304
107	1	BOTTOM PULLEY ACCES DOOR		STAINLESS STEEL 304
108	4	INSIDE HINGE DOOR		STAINLESS STEEL 304
109	4	HEXAGONAL BOW NUT	M8	STAINLESS STEEL A2
110	2	STOVED CAP SCREW	M6 - 12	STAINLESS STEEL A2
111	2	BEARING HANDLE DOOR		BRONZE
112	2	CLOSING HANDLE DOOR		STAINLESS STEEL 304
113	2	CROSS BAR LOCKET CLOSING DOOR		PEhd 500
114	2	LOCKET CLOSING DOOR		STAINLESS STEEL 304
115	2	STOVED SCREW	M6 - 8	STAINLESS STEEL A2
116	2	SAFETY BLOCK UPPER PULLEY		STAINLESS STEEL 304
117	2	STOVED SCREW	M4 - 8	STAINLESS STEEL A2
118	2	SHORT SCRAPER SUPPORT		STAINLESS STEEL 304
119	4	LONG SCRAPER SUPPORT		STAINLESS STEEL 304
120	6	FLAT WASHER	d8 - D16 - e1,5	STAINLESS STEEL A2
121	6	HEXAGONAL HEADED SCREW	M8 - 12	STAINLESS STEEL A2
122	2	SCRAPER SPRING BLADE TYPE 2		STAINLESS STEEL 301

REP.	NB.	DESIGNATION	BRAND	REFERENCE
E1	1	EMERGENCY STOP BUTTON IP65	TELEMECANIQUE	ZB4 BT4
E2	1	BLOCK CONTACT EMERGENCY STOP	TELEMECANIQUE	ZB4 BZ 102
E3	1	ON/OFF PUSH BUTTON WITH LIGHT	TELEMECANIQUE	ZB4 BW 833743
E4	1	TIGHTNESS CAP ON/OFF BUTTON	TELEMECANIQUE	ZBW 008A
E5	1	BLOCK CONTACT PUSH BUTTON ON/OFF	TELEMECANIQUE	ZB4 BW 0B15
E6	1	MAGNETIC SAFETY SWIFT IP67	SCHMERSAL	BNS 303 12Z
E7	1	MAGNET CODE	SCHMERSAL	BPS 300
E8	1	MAGNETIC SAFETY SWIFT IP67	SCHMERSAL	BNS 33 12Z
E9	1	MAGNET CODE	SCHMERSAL	BPS 33
E10	1	STUFFING BOX PG13,5	PROTEC	EPN 250 / PG13 9005
E11	1	BACK NUT STUFFING BOX PG13,5	PROTEC	EPN 355 / PG13 PS 9005
E12	1	LONG FEED FLEXIBLE CABLE 3 METRES	TITANEX	H07RNF 4G1,5
E13	1	FEEDING CONNECTOR 3 PHASES + EARTH	LEGRAND	55635
E14	1	ELECTRICAL BOX 250 x 195 x 90 IP65	MARLANVIL	010 . PL
E14a	1	MAGNETICAL SAFETY SUPERVISION BOX	SCHMERSAL	AES 7112
E14b	1	TRANSFORMER	TECH 39	LTT 7372
E14c	1	CONTACTOR	TELEMECANIQUE	LC1 D0910 B7
E14d	1	THERMIC PROTECTION RELAY	TELEMECANIQUE	LR2 D1310
E14e	1	FUSE HOLDER TERMINAL	SCHNEIDER	WK4/THS15U
E14f	1	TERMINAL EARTH	SCHNEIDER	WK4SL/U
E14g	1	FEED FLEXIBLE CABLE MOTOR LONG. 0,7 M	TITANEX	H07RNF 4G1,5
E14h	1	FEED FLEXIBLE CABLE BUTTON LONG. 1,5 M	REXEL	LIYY 4 * 0,5
E14i	3	WHITE FLEXIBLE WIRE	REXEL	H05 V-K 0,75
E14j	1	ORANGE FLEXIBLE WIRE	REXEL	H05 V-K 0,75
E14k	1	EARTH FLEXIBLE WIRE	REXEL	H07 V-K 1,5
E14l	1	BLACK FLEXIBLE WIRE	REXEL	H05 V-K 0,75
E14m	7	TERMINAL CABLE 0,5	SCHNEIDER	DZ5CE005
E14n	10	TERMINAL CABLE 0,75	SCHNEIDER	DZ5CE007
E14o	8	TERMINAL CABLE 1,5	SCHNEIDER	DZ5CE015
E14p	1	CABLE SOCKET PRE INSULATED BLUE	REXEL	
E14q	2	STUFFING BOX PG13,5	PHOENIX	ST 1.5 - TWIN
E15	2	BACK NUT STUFFING BOX PG13,5	PROTEC	EPN 250 / PG13 9005
E16	2	STUFFING BOX PG 9	PROTEC	EPN 355 / PG13 PS 9005
E17	1	BACK NUT STUFFING BOX PG9	PROTEC	EPN 250 / PG9 9005
E18	1	STUFFING BOX PG 7	PROTEC	EPN 355 / PG9 PS 9005
E19	2	BACK NUT STUFFING BOX PG7	PROTEC	EPN 250 / PG7 9005
E20	2	ENGINE BRAKE	PROTEC	EPN 355 / PG7 PS 9005
E21	1	EMERGENCY STOP BUTTON IP65	SEIMEC	HFV 90L6 1,5KW 230/400V B3

WARNING!

Any intervention on electrical wiring must be carried out by a qualified staff and absolutely only after having switched off the machine from the mains.

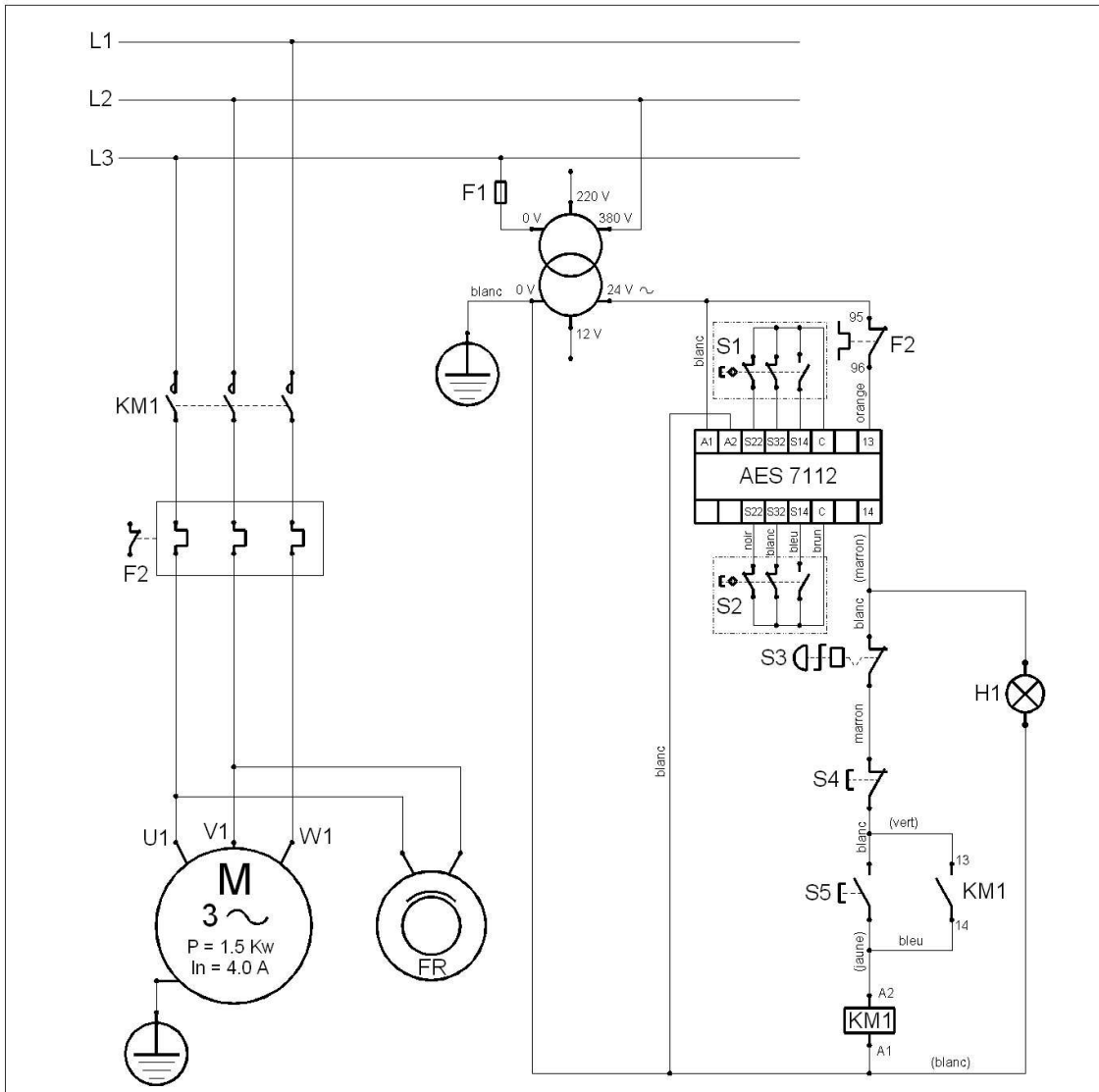

(...) : couleur de fil du câble multifilaire 4 x 0.5

REPÈRE	DESIGNATION
F1	FUSIBLE
S1	INTERRUPTEUR DE SECURITE MAGNETIQUE PORTE INFERIEURE
S2	INTERRUPTEUR DE SECURITE MAGNETIQUE PORTE SUPERIEURE
S3	BOUTON POUSSOIR D' ARRET D' URGENCE
S4	BOUTON POUSSOIR ARRET
S5	BOUTON POUSSOIR MARCHE
F2	RELAIS DE PROTECTION THERMIQUE
KM1	CONTACTEUR MARCHE
AES 7112	BOITIER SURVEILLANCE SECURITE MAGNETIQUE
M	MOTEUR ENTRAINEMENT LAME
FR	FREIN DE SECURITE MOTEUR
H1	VOYANT LUMINEUX



DESIGNATION : SCHEMA ELECTRIQUE SCIE SX 300

MACHINE : SX 300 - 300 S

Etabli le : 03/03/08

Modifié le :

Rep. : SC. COM. 1/1

ENGINE BRAKE MAINTENANCE

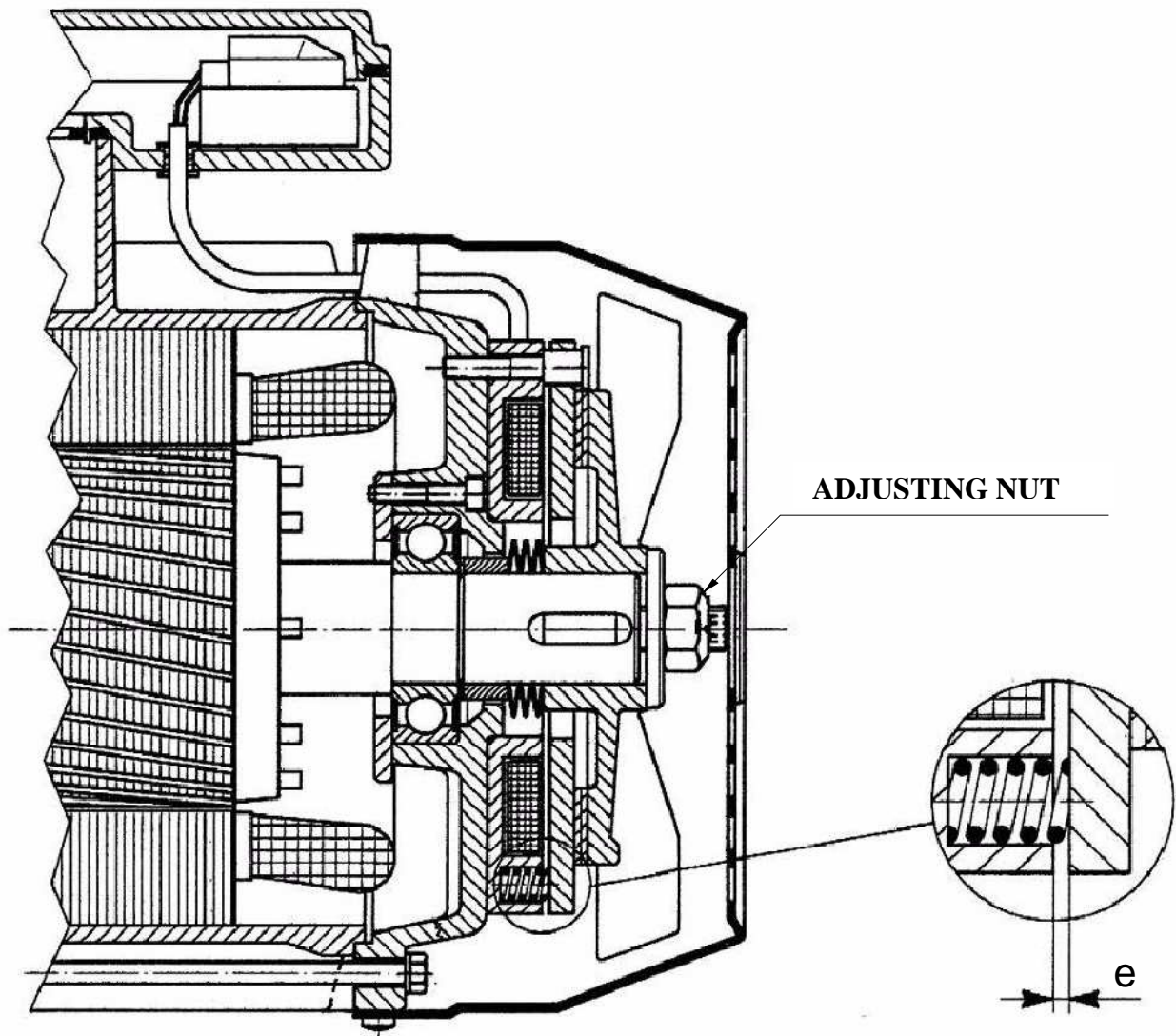

BE CAREFUL !

Brake maintenance must be done by a qualified staff and absolutely after having switched off the machine from the main line.

Check periodically that the Air Gap is included between 0.25 and 0.5 millimetre. An excessive value of the air gap due to friction packing wear make brake becomes less quiet and could create reduction of the braking moment or electric unclamping problems.

To adjust air gap with fitted fan cowl, man should act on adjusting nut, that is to know step is 1.25 mm.

After several air gap adjustments, check that the thickness packing friction do not becomes smaller than 1 mm ; if necessary change anchor brake.

USER MANUAL SAW SX 300 S

I PUTTING INTO PLACE

- 1.1 DELIVERY AND HANDLING.
- 1.2 DIMENSIONS AND SPECIFICATIONS.
- 1.3 INSTALLATION.
- 1.4 CONNECTING TO ELECTRIC NETWORK.

II PUTTING INTO SERVICE

- 2.1 ELECTRIC CONNECTION CHECK.
- 2.2 SAFETY AND PROTECTION STATE REPORT.

III INSTRUCTIONS FOR USE

- 3.1 USE PLANNED.
- 3.2 SPECIFIC POINTS.
- 3.3 PRELIMINARY ADJUSTMENTS.
- 3.4 START-UP.

IV MAINTENANCE.

- 4.1 PUTTING INTO PLACE CONTROL AND CHECKING.
- 4.2 PERIODIC CONTROLS .
- 4.3 CLEANING AND MAINTENANCE.

V WARRANTY.

VI ANOMALY.

VII ANNEXES.

- 7.1 OVERLOAD PROTECTION.
- 7.2 SOUND LEVEL.
- 7.3 STANDARDS AND INSTRUCTIONS.
- 7.4 TECHNICAL SOLUTIONS FOLLOWED TO MEET SAFETY REQUIREMENTS .
- 7.5 MACHINE PLAN.

I PUTTING INTO PLACE.

1.1 DELIVERY AND HANDLING.

- The dispatch material has been controlled carefully before being given to the carrier.
- On receipt of the machine, check the packaging.
- Express reservations in case of anomalies.
- The pallet can be moved with a pallet truck or a lift truck.
- Pull away the machine from its packaging cautiously. The saw can be removed from the pallet by lifting it up with a lift truck ; insert the forks under the frame between the feet according to information page 4.

1.2 DIMENSIONS AND SPECIFICATIONS.

Dimensions and specifications of saw SX 300 are specified page 3.

Reminder :

- Materials of the machine : stainless steel with a sanded or brushed appearance and polythene.
- Safety : doors and swivelling base magnetic protection, brake engine for blade stop in less than 4 seconds, operated system low tension.
- Pulleys diameter : 270 millimetres.
- Mass : 120 Kg.
- Engine power : 1.5 Kw.
- Blade dimension: 2170 x 16 x 0.5.
- Connection: tree-phase 230/400V, 50Hz.

1.3 INSTALLATION.

The saw must be set up in a stable strong and horizontal area. The height of the working plan is set at 870 millimetres. The floor must resist to the weight of the machine (120 Kg). One of the machine foot is adjustable in height in order to ensure its stability (Fig 1.3.1). Necessary space for saw use as well as user position are specified page 4. The saw should be set up in a sunny space.

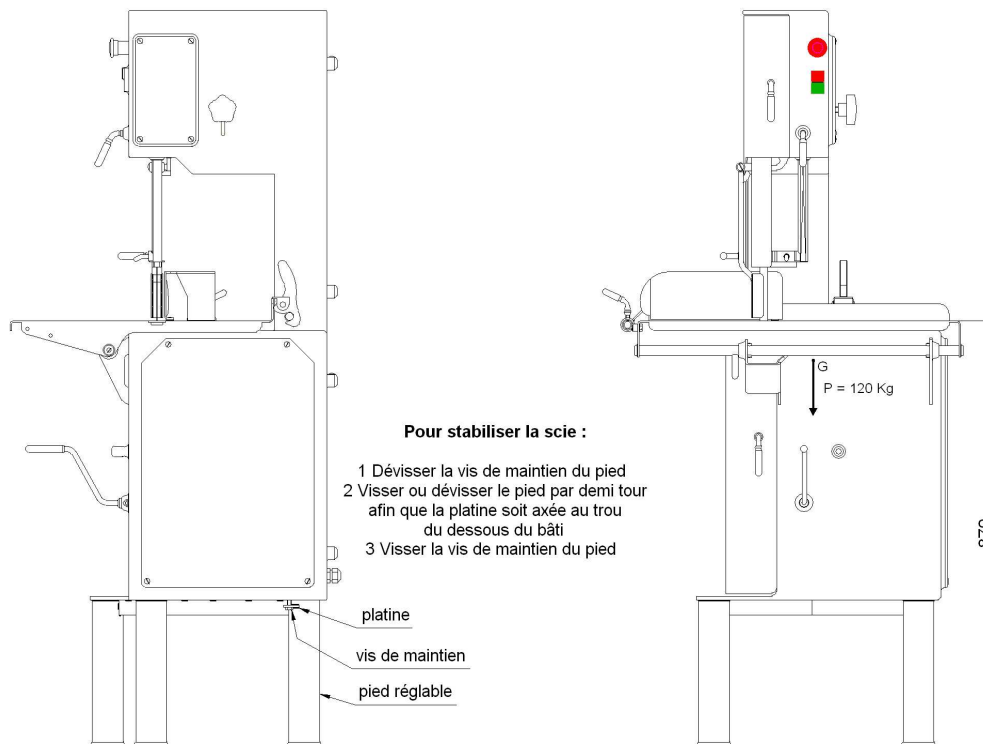

fig 1.3.1

1.4 CONNECTING TO ELECTRIC NETWORK.

The saw is delivered with a feed cable : 4 x 1,5 mm², length 3.5 m, and a connection plug 3 phases + earth (380V).

BE CAREFUL !

**Check that the feed line correspond to the tension and frequency indicated on the machinery identification plate.
If the saw is connect to the electrical network in a fixed way (without spitted plug), a section switch with a padlock must be installed.**

The connector must be putting in to an height between 0.6 and 1.9 metres and in a visible place in order to the user check that the machine is disconnected when he realize dangerous operations
The feed cable must have a section : 4 x 1,5 mm².

II PUTTING INTO SERVICE

2.1 ELECTRIC CONNECTION CHECK

During the first use you must check the pulleys rotation sense, that must turn anticlockwise.

1. Plug in the sector.
2. Pull the hand button safety stop.
3. Press the push button ON (green button).

The saw blade must moved in the arrow way as indicated on next drawing. If the rotation sense is the reverse way, disconnect the machine and et inverse two phases in the tree phase 20 A connector.

BE CAREFUL !

This operation must be done by par a technician entitled to this manipulation

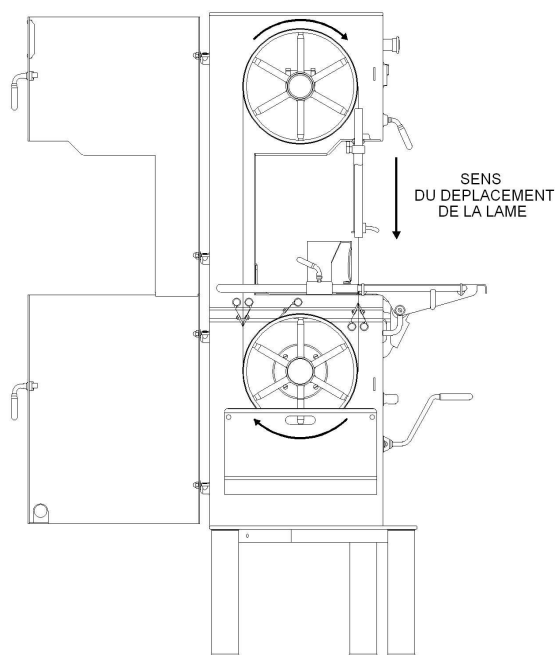

2.2 SAFETY AND PROTECTION STATE REPORT.

The saw SX 350 S is equipped with some safety and protection devices to avoid accident. It is necessary to control these devices during the start-up.

1. Mechanical devices:

Articulated push (rep 6 page 2) has been installed to protect blade access in cutting zone as well as to push the product against the blade. Check that this one is not damaged and that it automatically take place in front of the blade if we made it we swing it in any position.

An adjustable blade guard in height (rep 10 page 2) has been installed to protect the non use part of the blade ; a handle (rep 11 page 2) allows the keeping position of the blade guard. Check that the blade guard is not damaged, that it can slide up and down and that handle allows its le locking in the right position.

A swivelling base rotation axis integral device (rep 12 page 12) prevent the discharge of this one when bottom door is locked and the machine is working. The user must open bottom door to dump the base ; when the base is dumped, the door can not be closed and the machine can not work (both doors must be locked for the machine to run)

2. Electrical devices :

The operator is protected by a safety device on pulleys access doors close (rep E5 and E6 page 2) ; if this one open the bottom then the upon door for cleaning or maintenance, the machine does not work ; the upper door can not be opened without bottom door ; however the 2 doors are equipped with safety device If the machine is working and the user open the bottom door, the blade will stop in less than 4 seconds. Check by tests that doors safety devices work.

Normalization impose the blade stop for an opening of the door higher than 10 millimetres.

After a power cut, the user must press the push button ON to start up the machine again.

Then, check that, after pressing the button STOP or Emergency Stop, the blade stop in less than 4 seconds.

In case of the time for the blade to stop becomes too long, it is possible to adjust the engine brake air gap (see brake instructions page 14).

III INSTRUCTIONS FOR USE

3.1 USE PLANNED.

The saw SX 350 S must be used only by operators who had been trained during set-up.

The saw SX 350 S is provided to cut meat products, frozen products, bones or others alimentary products.

It is important to use every time the blade adapted to the product.

Cut only food products. Using forbidden for wood, plastic, steel.

3.2 SPECIFIC POINTS.

Before use, the operator must check that all saw components are at the right place (see components page 2) :

1. Swivelling base 12 horizontal position and locked by handle 13.
2. Bottom blade guide 25 in its place in swivelling base 12.
3. Saw blade 24 on pulleys 17 et 18 (voir 3.2.1). You must use gloves during blade handling.
4. Pulleys access doors 2 et 3 locked by closing handle 4.
5. Articulated push 6 placed in front of the blade 24.

3.2.1 BLADE FIXING.

BE CAREFUL : You must use gloves during blade handling.

To put on place the blade :

- 1) Disconnect network connector and open pulleys access doors 2 et 3.
- 2) Turn the handle 14 to the bottom to raise the lower pulley.



- 3) Pull the reinforced base 29 and insert the blade in swivelling base slot 12 ; teeth moved to the outside and the low. Lift the articulated push 6 and put the blade behind, insert it in blade guides 25 et 26 then put it on upper pulley.

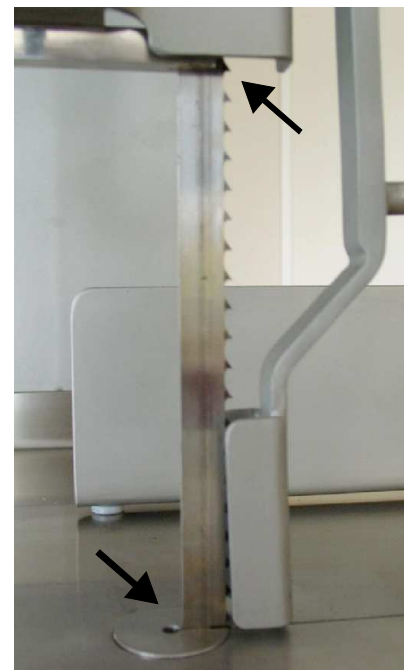

- 4) Put the blade between the scrapers situated under blade guide 25 of swivelling base 12, then bottom pulley and at last between scrapers on the right of the bottom pulley.

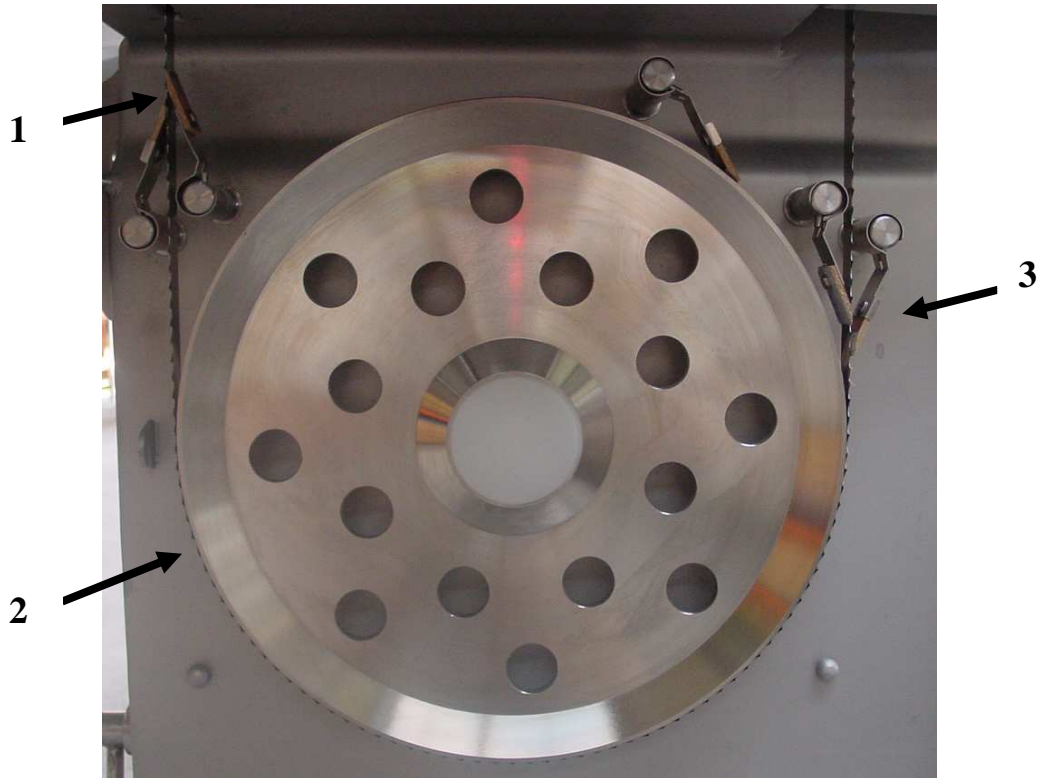

- 5) Check the blade is in thrust against pulleys shoulder then turn the handle 14 to the top so as to stretch the blade.



- 6) Locked the reinforced base 29 and the pulleys access doors 2 et 3 with handles 4.



Saw blades recommended :

- 2170 x 16 x 0.5 réf. VO : blade for meat and bones.
- 2170 x 16 x 0.5 réf. V : blade for meat.
- 2170 x 16 x 0.5 réf. C : blade for frozen meat.

3.3 PRELIMINARY ADJUSTMENTS.

Before cutting any products, it is necessary to adjust the height of the blade guard 10 at the nearest top of the product ; locked in position with the handle 11.

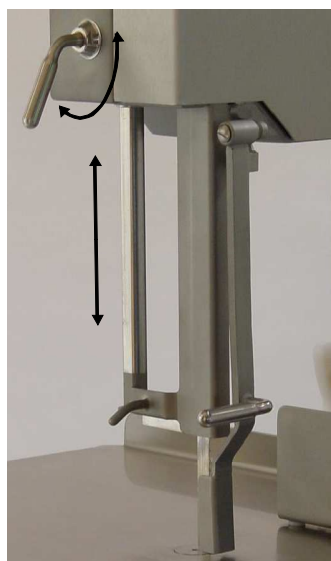

The thickness cutting guide 7 allows the production of same thickness slices. After having unscrew the handling screw 9, you can place the guide to obtain the wished thickness. You have to screw the handling screw 9 to fix the guide in wished position.

3.4 START-UP

- 1) Connect to the main line.
- 2) Put the product to cut on the machine table 12.
- 3) Pull the emergency button E3 and push the ON green button E4.
- 4) Push the product against the blade with the articulated push 6 with one hand and hold up the furthest part of the product with the other hand. Act a light pressure (a pressure too important will bend the blade and the cut will not be straight).
- 5) To stop the machine, push on the STOP red button E4

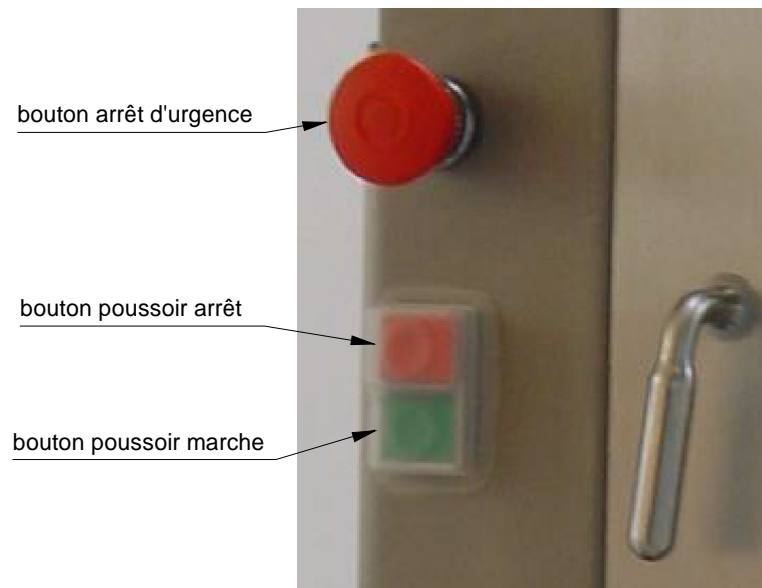

Attention : it is forbidden to saw without using articulated push.

It is recommended to release the band blade each end of day to preserve its duration of life.

IV MAINTENANCE

4.1 CONTROL AND VERIFICATION FOR THE PUTTING ON PLACE.

- Control the state of the frame, the door and the safety components (see 2.2).
- Check that the feed tension correspond to the indicated value on machine identification plate.
- Check the sense of blade rotation (see 2.1).
- Check the position of the blade on bottom pulley ; if the position is not correct (see drawings here after) unscrew the locked handle 16 then screw or unscrew the adjusting screw 15 of the pulley according to each case. After adjustment, screw the handle 16 handling the adjusting screw 15 in order to locked this one in position.

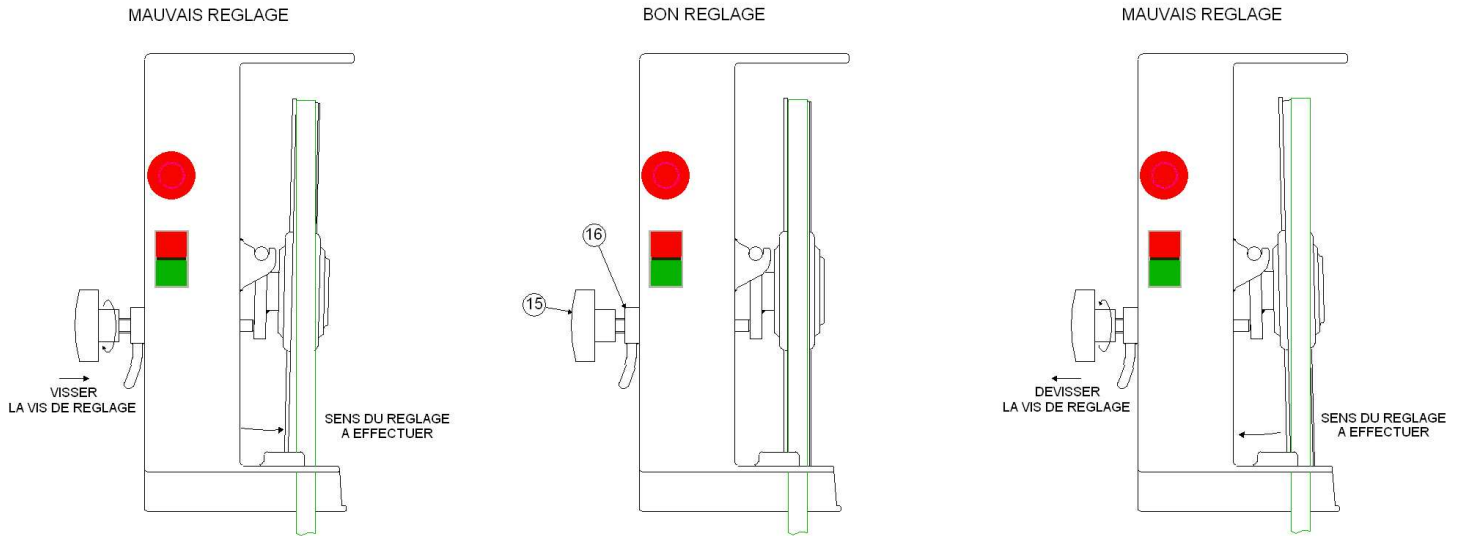

- The tarring of the blade tension spring is done at the plant. Nevertheless it is possible to adjust blade tension with adjusting nut and back nut situated on the top of the engine platine spring (screw to stretch, unscrew to release). You must put the machine off-tension and open engine access door to do this operation (rep 137).

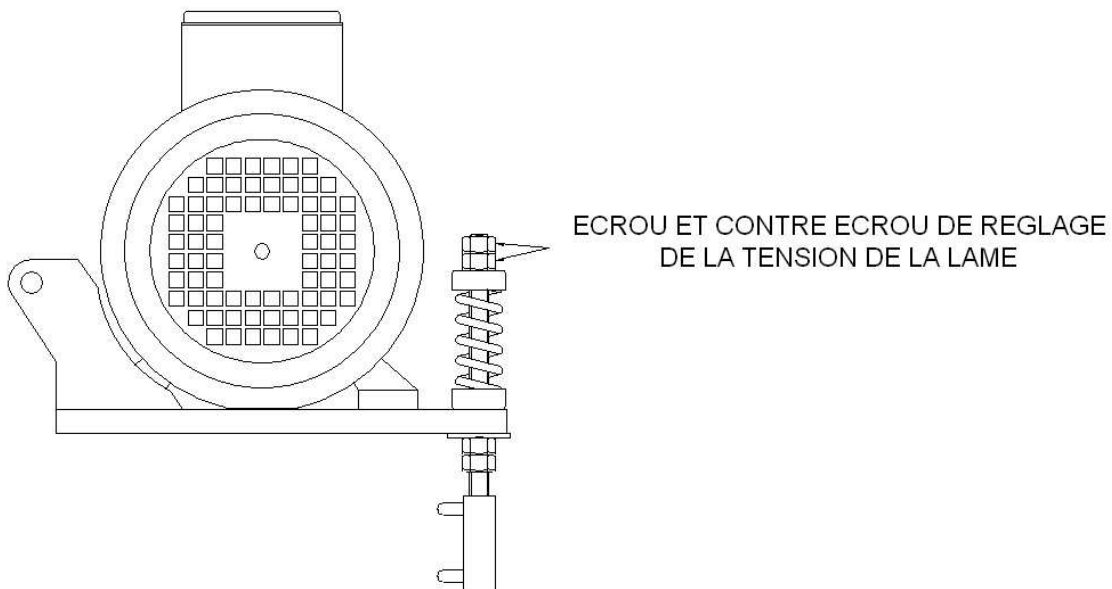

ATTENTION !

This two last adjustments must be done by par a technician entitled to this manipulation

4.2 PERIODIC CONTROLS

When the putting on place is done, preservation of reliability and results of your saw needs very few interventions. However, it is necessary to control periodically scrapers state, these ones must always be in contact with the blade and bottom pulley ; blade scrapers must always be change by pair.

To change scrapers:

- Disconnect the main line.
- Open pulleys access doors.

- Take away the spring blade 120 (this one is just set in its support 116).
- Unscrew the nut 124 to put away used scraper.
- Put on place a new scraper, screw the nut 123 and replace the spring blade 120 on support 116.

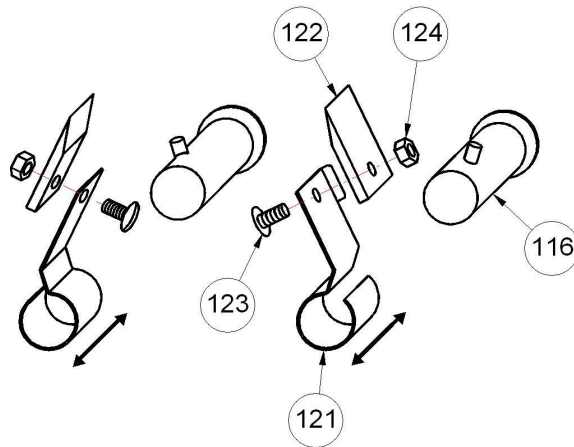

You must control the state of the blade as well ; actually, if you must exert an important pressure to cut the product, it means that the blade is used and must be changed. Concerning the lubrication, you have to oil weekly the slide 8 of the cutting thickness guard and the blade guard slide 10 with feeding grease to get a good sliding.

4.3 CLEANING AND MAINTENANCE

BE CAREFUL !

The machine must be disconnected during any cleaning operation

You must do a daily cleaning removing all residues after each use.

Cleaning of the machine :

- 1) Open pulleys access doors.
- 2) Dismantle the blade, the bottom blade guide, as well as scrapers ; dip and clean those carefully..
- 3) Dismantle the upon pulley and its support.

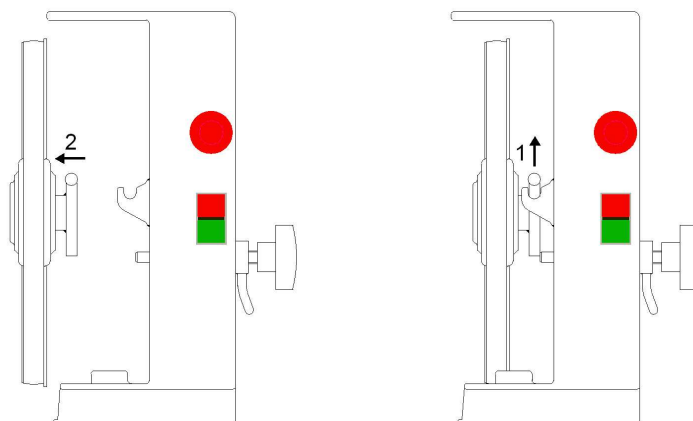

- 4) Take away the cut thickness guide ; unscrew its handling screw from 3 turns, tip it over then pull it away from its slide.
- 5) Tip over the swivelling base after having unlocked handling handle.
- 6) Rinse it with water in order to remove organic material (warm or cold water).
- 7) Brushing material.
- 8) Detergency warm water 40 to 55°C to remove stain.
- 9) Rinse with water to remove any traces of detergent and organic material
- 10) Disinfections to remove any germs
- 11) Final rinse required to remove any disinfecting product residue.
- 12) Draining or drying without wiping to avoid new contamination of the cleaning surface by germs.

Possibly :

- 13) Acid detergents for mineral deposit dissolving (ex : tartar). Its usage frequency depends of the material function, the product and treatment of the product.
- 14) Rinse with clear water to remove any acid products and mineral material traces.

Attention :

- **Only drinking water is allowed for cleaning operations.**
- **Do not use an high pressure cleaning machine.**
- **Use detergent products compatible with STAINLESS STEEL 304 (X5 Cr Ni 18-10) and POLYETHYLENE 500 (PEhd 500)**

The main detergents disinfectants used in food-processing sector are les alkaline chlorinated. We recommend you the use of these products that are compatibles with using materials in our saw conception.

V WARRANTY

Any modification of the machinery is forbidden.

In case of anomaly, please contact after-sales service.

The manufacturer takes no responsibility in the event of :

- Putting on place no correct.
- Using no correct of the machinery.
- Contrary use from country using clauses.
- Bad maintenance.
- Modification or replacement of components by non-original pieces.
- Modification of original adjustments without special authorization.

Warranty valid 1 year.

VI ANOMALY.

Descriptive board of first intervention in case of anomaly.

STATEMENT	CAUSES	SOLUTIONS
The saw doesn't start-up	<ul style="list-style-type: none">- Emergency Stop button engaged.- Doors or swivelling base unlocked.-Safety defective.	<ul style="list-style-type: none">- Pull Emergency button.- Check unlock of doors or swivelling base.- Call after-sales department.
Counter clockwise blade rotation	<ul style="list-style-type: none">- Reversed connexion.	<ul style="list-style-type: none">- See item 2.1.
Blade tension too low	<ul style="list-style-type: none">- Handle not turn enough- Tension spring not stretch enough	<ul style="list-style-type: none">- Turn the handle counter clockwise- See item 4.1 or call after-sales department
Blade tension too high	<ul style="list-style-type: none">- Tension spring too stretched	<ul style="list-style-type: none">- See item 4.1 or call after-sales department
The band saw doesn't keep in place on pulleys	<ul style="list-style-type: none">- Upon pulley is disturbed	<ul style="list-style-type: none">- See item 4.1.
The product is not cutting well	<ul style="list-style-type: none">- Blade is used	<ul style="list-style-type: none">- Change the blade.
The blade stop in more than 4 seconds	<ul style="list-style-type: none">- Engine brake is disturbed	<ul style="list-style-type: none">- Call after-sales department.

VII ANNEXES

7.1 OVERLOAD PROTECTION

Engine nominal intensity is 4 amperes. The protection value against engine thermal relay overload is of 15 % higher.

7.2 SOUND LEVEL

Sound pressure level of the saw SX 300 S is 85 decibels maximum.

7.3 STANDARDS AND INSTRUCTIONS

Usual standards and instructions for the saw SX 350 S conception are :

- European standards band saws EN 12268.
- European machines security standards EN 60204-1.
- European instructions 98 / 37 / CE.

:

7.4 TECHNICAL SOLUTIONS FOLLOWED TO MEET SAFETY REQUIREMENTS

REQUEST	RISKS	TECHNICAL SOLUTIONS
<p>1.1.2 Principles for safety integration.</p>	<p>Risk during using operations, adjustment, maintenance.</p> <ul style="list-style-type: none"> - Injury and cut risk outside of cutting area. - Injury and cut risk in cutting area. - Hand jamming risk between wheel and blade. - Injury risk in case of tipping out of the swivelling base. - Injury risk in transmission moving components. 	<ul style="list-style-type: none"> - Pulleys access doors equipped with locking devices as blade stop is done in less than 4 seconds after opening doors from 10 millimetres. - Adjusting and dismantling protective only with a tool for the non-used part of the blade. - Articulated push protecting the blade access that takes automatically place on protection position ; the distance between push and table is less than 6 mm. - Adjusting slice thickness height 105 mm - Wheels access protected by 2 locked doors - Each risk of base tipping out is avoided by an handling handle. And swivelling base is equipped with a mechanical device that avoid the base from a tipping out when door is closed and saw is running. - Engine and transmission components are protected by a fix and dismantled protective only with a tool. - In any case, an emergency stop device is available for the operator.
<p>1.1.3 Materials and products.</p>	<p>Safety and health risks.</p>	<ul style="list-style-type: none"> - Used material for machinery construction is a stainless steel in accordance with food processing manufacturing machine. The machine is realized in accordance with machine directives (flow of liquids, no retention of organic materials, method and means cleaning recommended in user manual). Surfaces roughness on food area is less than 16 micrometers.

REQUEST REQUEST	RISKS RISKS	TECHNICAL SOLUTIONS TECHNICAL SOLUTIONS
8.1 – 8.2 – 8.3 E2 Commands. Electric protection.	<ul style="list-style-type: none"> - Electrical collision risk due to electric components non insulated. - Risk in case of error of operation. - Electrical collision risk due to electric components insufficiently protected against water splashing. - Start-up without operator. - Dangerous situation due to a lack of stop device. - Physical injury after an energy power cut. 	<ul style="list-style-type: none"> - Electric equipment of the machine is in accordance with an examination from standards EN 60204-1 (protection against direct contact) - Machine with simple using included a safety device to avoid accident. - Water protect is ensure by casing for which protection indicator is : - Order components clearly visible and identifiable for an easy and sure use. - IP X 3 : external electric components. - IP X 3 : internal electric components - The start-up can only be done by an action from the operator on the push button ON. The button ON is set back from the button OFF - Stop function – Device in accordance with the category 0 describe § 9.2.2 standard EN 60204-1. - The machine is equipped with a STOP button with disabled access. It has as well an emergency button. - The start-up after a power cut can only be realized after a push on the ON button. - Different order mediums are supplied in 24 volts and connected to earth. - Conductive machine components are connected to earth by a terminal located in electrical box. - The engine machine is linked to an earth
1.3.1 Stability.	<ul style="list-style-type: none"> - Tipping out of the machine and physical injury risks 	<ul style="list-style-type: none"> - Machine stability is ensure by its non wheel (no wheels). - And due to gravity centre position, the machine is steady during its use in usual conditions planned.
		<ul style="list-style-type: none"> - Caoutchouc foot plug 75 mm diameter for a good adhesion on the floor.

7.5 MACHINE PLAN.

See SX 300 S complete plan

DECLARATION CE DE CONFORMITE

LA SOCIETE

DADAUX _____

LE BOUCHAUD _____

39800 BERSAILLIN - POLIGNY _____

N° TVA : FR 37333076248 _____

DECLARE QUE

LA SCIE A RUBAN _____

TYPE SX 300 S N° _____

DE MARQUE DADAUX _____

EST CONFORME

A LA DIRECTIVE EUROPEENNE 2006/42/CE.

LA FABRICATION DE CETTE MACHINE EST CONFORME AUX NORMES SUIVANTES : PR
NF EN 12268 ET EN 60204-1.

BERSAILLIN LE _____

MR DADAUX Jean-Claude, P.C.A.

